

HotSpot Energy Inc.  
Solar Air Conditioner Service  
Manual  
ACDC12C / ACDC18C

Indoor Units:  
ACDC12C-IDU  
ACDC18C-IDU

Outdoor Units:  
ACDC12C-ODU  
ACDC18C-ODU

Version 3

## Table of Contents

<b>Installer Warnings</b> .....	1
<b>1. Safety Precautions</b> .....	2
<b>2. Specifications</b> .....	3
2.1. Unit Specifications .....	3
2.2. Operation Characteristic Curve.....	5
2.3. Capacity Variation Ratio According to Temperature.....	5
2.4. Operation Data .....	6
2.5. Noise Criteria Curve Tables for both Models.....	6
<b>3. Construction Views</b> .....	7
3.1. Indoor Unit .....	7
3.2. Outdoor Unit .....	8
<b>4. Refrigerant System Diagram</b> .....	9
<b>5. Schematic Diagram</b> .....	12
5.1. Indoor Electrical Wiring .....	12
5.2. Outdoor Electrical Wiring .....	13
<b>6. Function and Control</b> .....	14
6.1. Remote Control Operations .....	14
6.2. Functions Buttons .....	15
6.3. Usage .....	19
6.4. Display Status.....	21
<b>7. Installation Manual</b> .....	22
7.1. Notices for Installation .....	22
7.2. Installation Drawing .....	25
7.3. Install Indoor Unit .....	26
7.4. Install Outdoor Unit .....	28
7.5. Install PV-Module.....	29
7.6. Check after Installation and Operation Test.....	34
7.7. Installation and Maintenance of Healthy Filter.....	34
<b>8. Exploded Views and Parts List</b> .....	35
8.1. Indoor Unit .....	35
8.2. Outdoor Unit.....	36
<b>9. Troubleshooting</b> .....	37
9.1. Error Code .....	37

## **INSTALLERS, Please read the following warnings to prevent voiding warranties:**

**WARNING:** Make sure the PV panels are wired in SERIES, NOT PARALLEL. Verify voltage is within range prior to connecting to the ODU DC breaker.

**WARNING:** Voltage from breaker box to ODU disconnect should be 220V (measured between L1 and L2.)

**WARNING:** Do not use the SIGNAL WIRE as the POWER LINE (L1, L2) or Ground.

**WARNING:** Connect: (AC – AC) and the (DC – DC), at the ODU.

**WARNING:** The unit does not export power, it cannot send power to the grid, there is no “output” and it does not need a grid interactive connection for the solar assist.

**WARNING:** The rated DC voltage of 380 is the “voc” rating, the ACDC12c uses the “vmp” rating which is 300 vdc max.

**WARNING:** When attaching the solar PV cables follow the markings on the MC4 connectors for proper polarity. Failure to do so will damage the air conditioner. Use a volt meter to locate the positive cable.

The unit has UL/ETL/CSA approval, see

<https://ramuk.intertekconnect.com//WebClients/ITS/DLP/products.nsf/vwSearch?SearchView&Query=FIELD%20ListHead%20Contains%20chiltrix%20or%20FIELD%20CatCode%20Contains%20chiltrix%20or%20FIELD%20Title%20Contains%20chiltrix%20or%20FIELD%20ProductInformation%20Contains%20chiltrix%20or%20FIELD%20ProductInfo%20Contains%20chiltrix&SearchOrder=1&SearchMax=1000&SearchWV=FALSE&SearchThesaurus=FALSE&SearchFuzzy=FALSE>

# 1. Safety Precautions

Installing, starting up, and servicing air conditioner can be hazardous due to system pressure, electrical components, and equipment location, etc.

Only trained, qualified installers and service personnel are allowed to install, start-up, and service this equipment.

Untrained personnel can perform basic maintenance functions such as cleaning coils. All other operations should be performed by trained service personnel.

When handling the equipment, observe precautions in the manual and on tags, stickers, and labels attached to the equipment. Follow all safety codes. Wear safety glasses and work gloves. Keep quenching cloth and fire extinguisher nearby when brazing.

Read the instructions thoroughly and follow all warnings or cautions in literature and attached to the unit. Consult local building codes and current editions of national as well as local electrical codes.

Recognize the following safety information:

 **Warning** Incorrect handling could result in personal injury or death.

 **Caution** Incorrect handling may result in minor injury, or damage to product or property.

---

 **Warning**

All electric work must be performed by a licensed technician according to local regulations and the instructions given in this manual.

- Before installing, modifying, or servicing system, main electrical disconnect switch must be in the OFF position. There may be more than 1 disconnect switch. Lock out and tag switch with a suitable warning label.
- Never supply power to the unit unless all wiring and tubing are completed, reconnected and checked.
- This system adopts highly dangerous electrical voltage. Incorrect connection or inadequate grounding can cause personal injury or death. Stick to the wiring diagram and all the instructions when wiring.
- Have the unit adequately grounded in accordance with local electrical codes.
- Have all wiring connected tightly. Loose connection may lead to overheating and a possible fire hazard.

All installation or repair work shall be performed by your dealer or a specialized subcontractor as there is the risk of fire, electric shock, explosion or injury.

- Make sure the outdoor unit is installed on a stable, level surface with no accumulation of snow, leaves, or trash beside.
- Make sure the ceiling/wall is strong enough to bear the weight of the unit.
- Make sure the noise of the outdoor unit does not disturb neighbors.
- Follow all the installation instructions to minimize the risk of damage from earthquakes, typhoons or strong winds.
- Avoid contact between refrigerant and fire as it generates poisonous gas.
- Apply specified refrigerant only. Never have it mixed with any other refrigerant. Never have air remain in the refrigerant line as it may lead to rupture and other hazards.
- Make sure no refrigerant gas is leaking out when installation is completed.
- Should there be refrigerant leakage, the density of refrigerant in the air shall in no way exceed its limited value, or it may lead to explosion.
- Keep your fingers and clothing away from any moving parts.
- Clear the site after installation. Make sure no foreign objects are left in the unit.
- Always ensure effective grounding for the unit.

---

 **Caution**

- Never install the unit in a place where a combustible gas might leak, or it may lead to fire or explosion.
- Make a proper provision against noise when the unit is installed at a telecommunication center or hospital.
- Provide an electric leak breaker when it is installed in a watery place.
- Never wash the unit with water.
- Handle unit transportation with care. The unit should not be carried by only one person if it is more than 20kg.
- Never touch the heat exchanger fins with bare hands.
- Never touch the compressor or refrigerant piping without wearing glove.
- Do not have the unit operate without air filter.
- Should any emergency occur, stop the unit and disconnect the power immediately.
- Properly insulate any tubing running inside the room to prevent the water from damaging the wall.

## ACDC12C Specifications

Power AC	208-240V, 50/60Hz	Power DC, PV, series connection	100-300 Vmp
*Cooling Capacity	12,000 BTU/h	Solar Power Input	<math>\leq 15a</math>
Power Input @ Full Cooling Operation	960W	Outdoor Range (cooling/heating)	20F-125F / 5F-86F
Avg. Power Consumption, Cooling	544W	Outdoor Noise Level Max	53 dB(a)
Cooling EER / COP at 100% power	12.5 / 3.66	Outdoor Fan Motor	Welling BLDC
SEER / SEER w/ solar calculation	>22 / >75	Outdoor Air Flow CFM max.	1150
*Heating Capacity	12,000 BTU/h	Outdoor Unit, weight	71 Lbs.
Power Input @ Full Heating Operation	1028W	Outdoor Unit Dimension (W*D*H)	34" x 13" x 22"
Avg. Power Consumption, Heating	601W	Compressor	Toshiba/GMCC Rotary
Heating COP	3.42	Refrigerant / Oz. / G.	R410A / 44.1oz. / 1150g
HSPF	11	Max. Lineset / Max. Elevation (Ft.)	50 ft. / 16 ft.
Indoor Fan Motor	BLDC	Moisture Removal	1.3 L/h
Indoor Fan Input (Highest speed)	23W	Rated Current (RLA)	5.9A
Indoor Fan RPM (Hi/Med/Lo)	1250/1000/850	Locked Rotor Amp (LRA)	.58
Indoor Air Flow CFM	360/340/295	Refrigerant Oil	VG74 / 370 ml
Indoor Noise Level (Hi/Med/Lo)	41/38/32 dB(a)	Design Pressure	550/340 PSIG
Indoor Unit Dimensions (W*D*H)	34" x 8" x 12"	Liquid side/ Gas side	1/4" / 3/8" Flare
Indoor Unit Weight	22 Lbs.	Certifications	ETL / UL, Energy Star

All specifications subject to change without notice. Images for reference only. See website for full details on operation and requirements.  
 \*BTU capacity may be reduced when solar power is limited. An AC backup connection is recommended for full & uninterrupted operation.

## ACDC18C Specifications

Power AC	208-240V, 50/60Hz	Power DC, PV, series connection	110-300 Vmp
*Cooling Capacity (rated/max) BTU	17,000 / 18,015	Solar Power Input	</=10a
Power Input @ Max Cooling	1360W	Outdoor Range (cooling/heating)	50F-125F / 6F-86F
Avg. Power Consumption, Cooling	819W	Outdoor Noise Level Max	56 dB(a)
Cooling EER / COP at Rated Cooling	13.25/ 3.88	Outdoor Fan Motor	Variable BLDC
SEER / SEER w/ solar calculation	>22 / >75	Outdoor Air Flow CFM max.	1250
*Heating Capacity	18,083 BTU	Outdoor Unit, weight	124 Lbs.
Power Input @ Rated Heating	1360W	Outdoor Unit Dimension (W*H*D)	955×700×390 mm
Avg. Power Consumption, Heating	700W	Compressor	Toshiba/GMCC 2xRotary
Heating COP	3.89	Refrigerant g/oz	R410A 1600/56.5
Max power Input	1900W	Max. Lineset / Max. Elevation (Ft.)	50 ft. / 16 ft.
Indoor Fan Motor	BLDC	Moisture Removal	1.9 L/h
Indoor Fan Input (Highest speed)	40W	Rated Current (RLA)	7.13A
Indoor Fan RPM (Hi/Med/Lo)	1180/1010/850	Locked Rotor Amp (LRA)	1.2a
Indoor Air Flow CFM	360/340/295	Refrigerant Oil	VG74 / 480 ml
Indoor Noise Level (Hi/Med/Lo)	41/38/33 dB(a)	Design Pressure	550/340 PSIG
Indoor Unit Dimensions (W*H*D)mm	970×315×242	Liquid side/ Gas side (Flare)	φ6.35*0.5+φ15.88×0.75
Indoor Unit Weight	30 Lbs.	Certifications	ETL / UL, Energy Star

All specifications subject to change without notice. Images for reference only. See website for full details on operation and requirements. \*Off-grid BTU capacity will be reduced when solar power is limited. An AC backup connection is recommended for full & uninterrupted operation. Extra panels, up to eight, should be used for intended off-grid applications.

## 2.2 Operation Characteristic Curve

Cooling

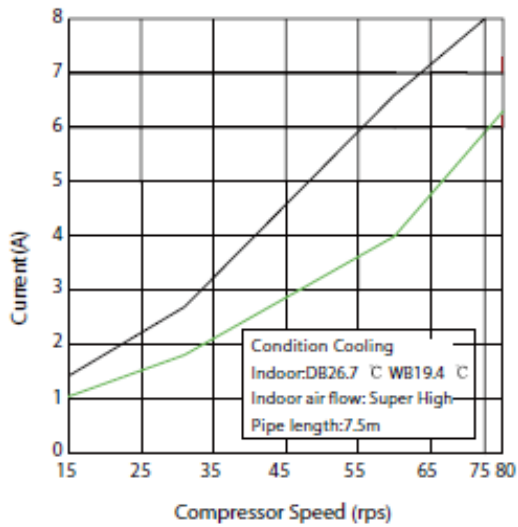

Heating

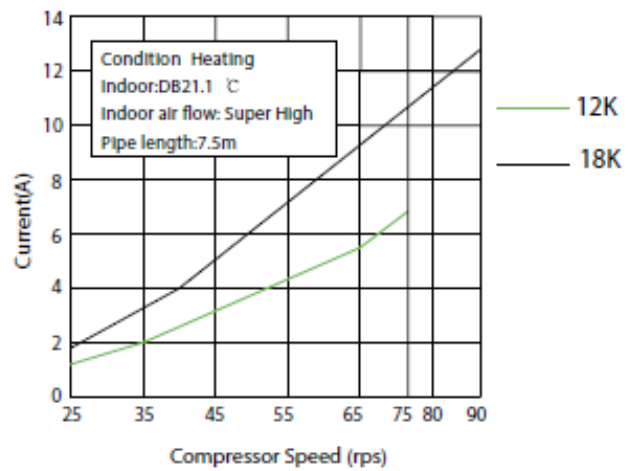

## 2.3 Capacity Variation Ratio according to Temperature

Cooling

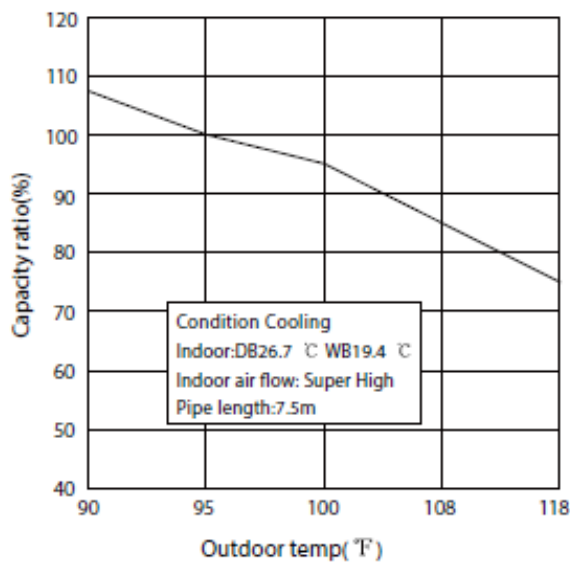

Heating

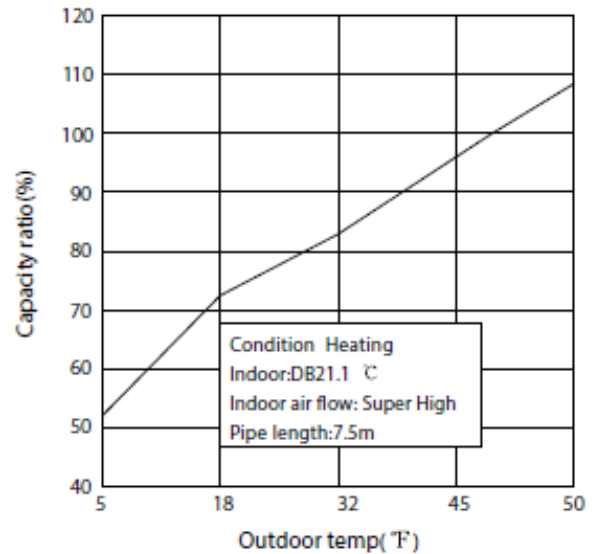

## 2.4 Operation Data

### Cooling

Temperature condition (°C)		Model name	Standard pressure P (MPa)	Heat exchanger pipe temp		Indoor fan mode	Outdoor fan mode(rpm)	Compressor revolution
Indoor	Outdoor			T1 (°C)	T2 (°C)			
26.9/19.4	35/23.9	12K	0.8 to 1.1	11 to 14	38 to 70	Super High	900/680	rated
		18K	0.9 to 1.3	9 to 12	38 to 65	Super High	690/500	rated

### Heating

Temperature condition (°C)		Model name	Standard pressure P (MPa)	Heat exchanger pipe temp		Indoor fan mode	Outdoor fan mode(rpm)	Compressor revolution
Indoor	Outdoor			T1 (°C)	T2 (°C)			
21.1/15.6	8.33/6.11	12K	2.8 to 3.2	42 to 70	0 to 3	Super High	900/680	rated
		18K	2.8 to 3.5	46 to 80	0 to 3	Super High	690/500	rated

**T1: Inlet and outlet pipe temperature of evaporator**

**T2: Inlet and outlet pipe temperature of condenser**

**P: Pressure of air pipe connecting indoor and outdoor units**

#### NOTES :

(1) Measure surface temperature of heat exchanger pipe around center of heat exchanger path U bent. (Thermistor thermometer)

(2) Connecting piping condition : 7.5m

## 2.5 Noise Criteria Curve Tables for both Models

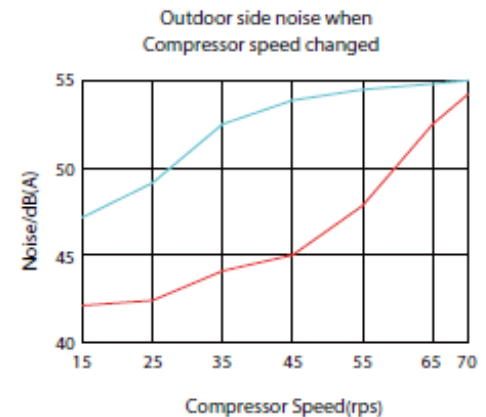
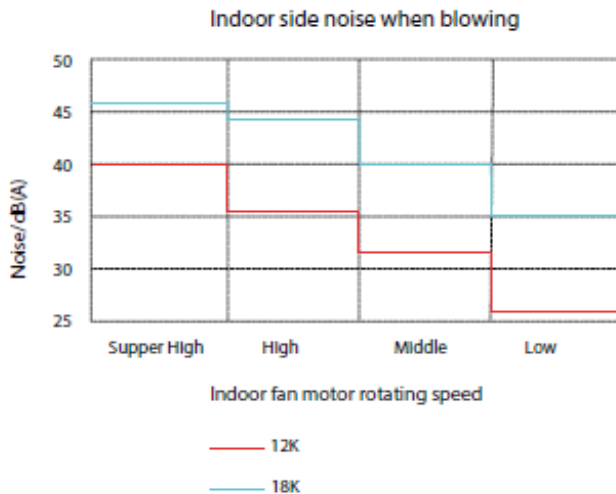



### 3. Construction Views

#### 3.1 Indoor Unit

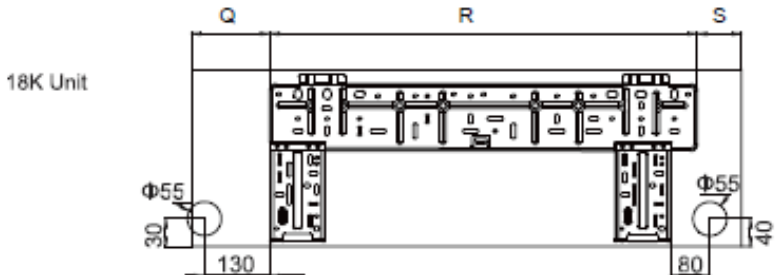
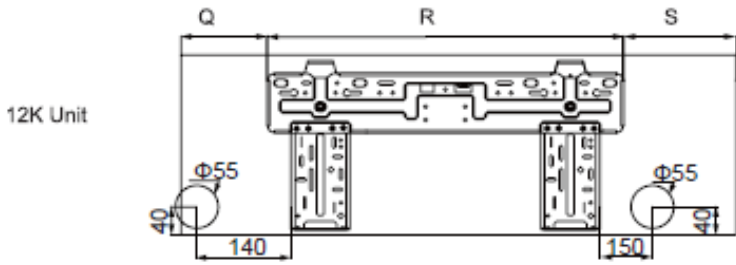
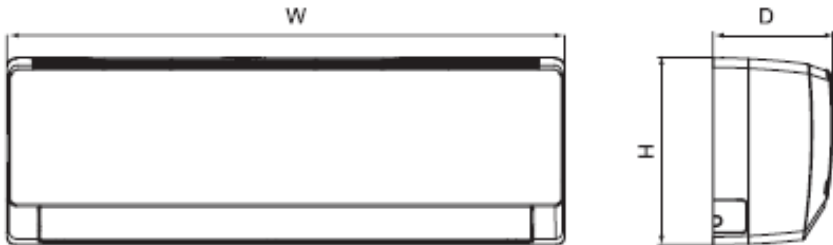

Unit:mm

Model	W	H	D	Q	R	S
12K	850	300	205	170	534	150
18K	970	315	242	198	610	160

### 3.2 Outdoor Unit

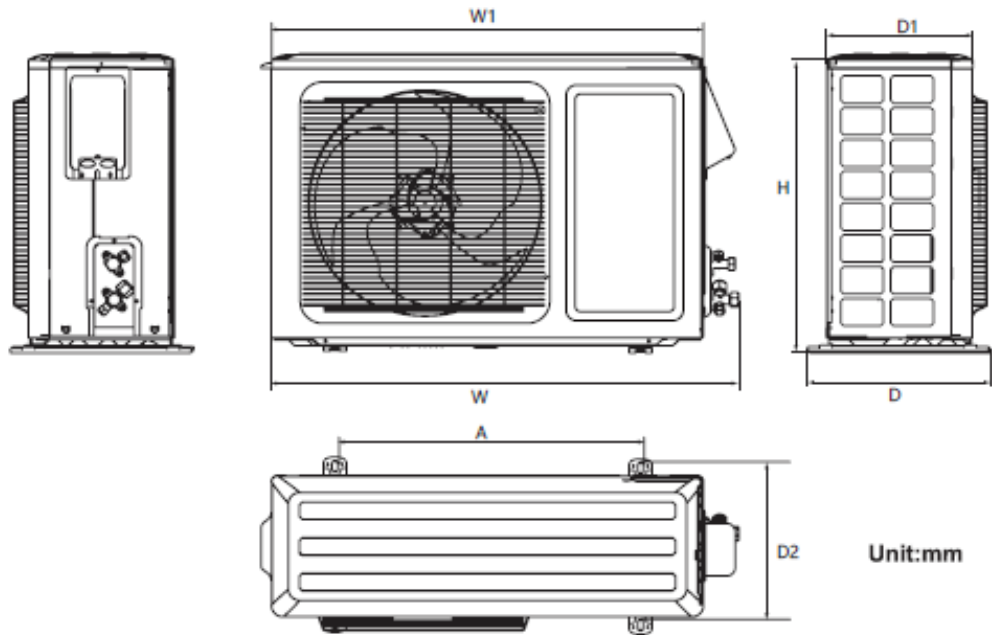

Unit:mm

Unit:mm

Model	W	H	D	W1	A	D1	D2
12K	860	540	355	790	545	290	315
18K	955	700	390	890	632	320	350

## 4. Refrigerant System Diagram

1) Cooling Only  
Cooling mode

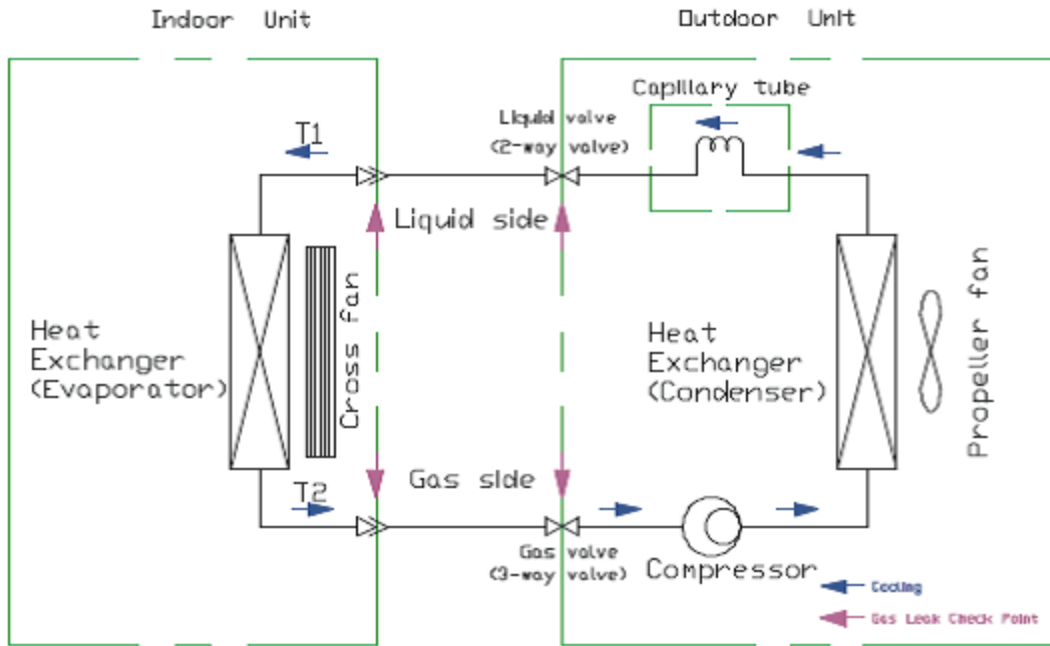

Cooling Cycle

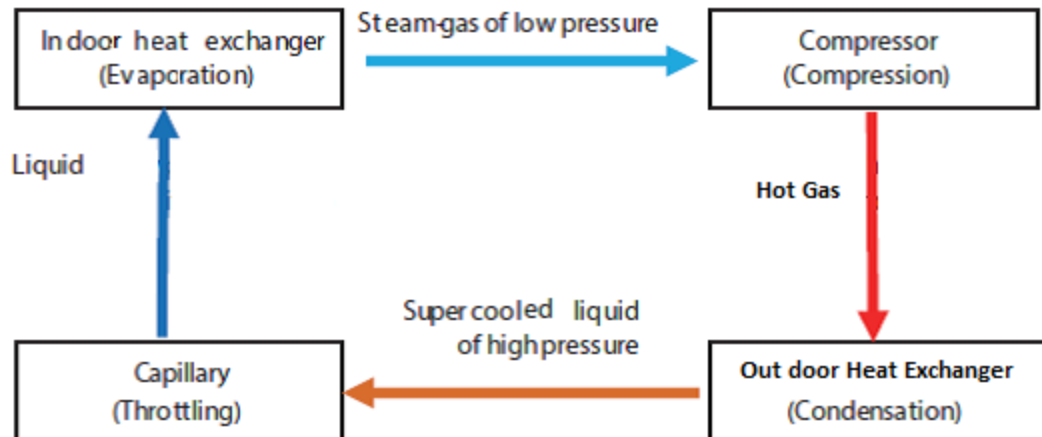

## 2) Cooling & Heating

### Cooling Mode

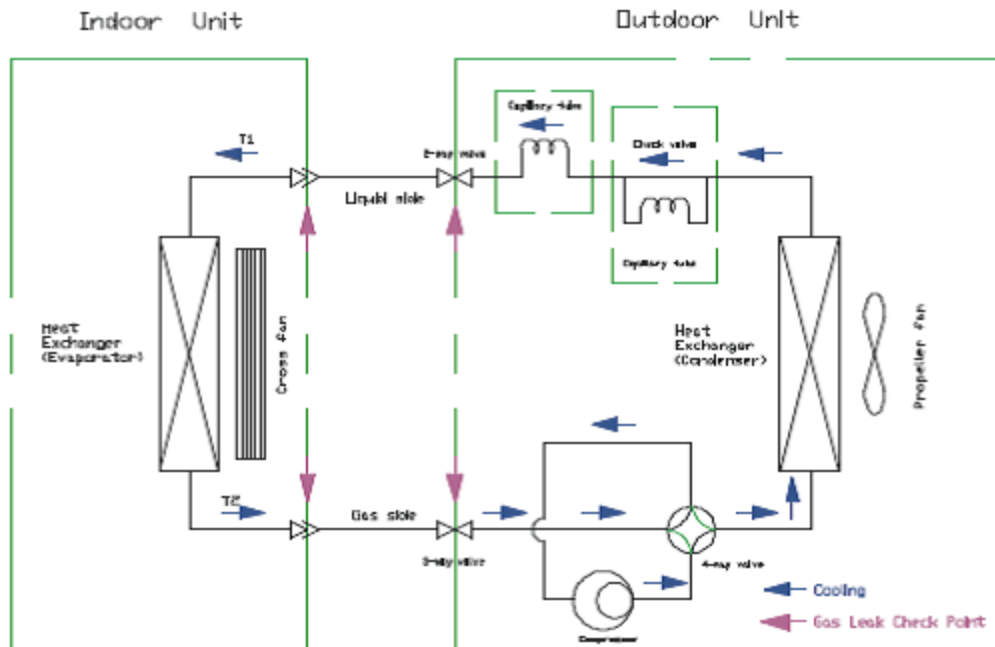

### Cooling Cycle

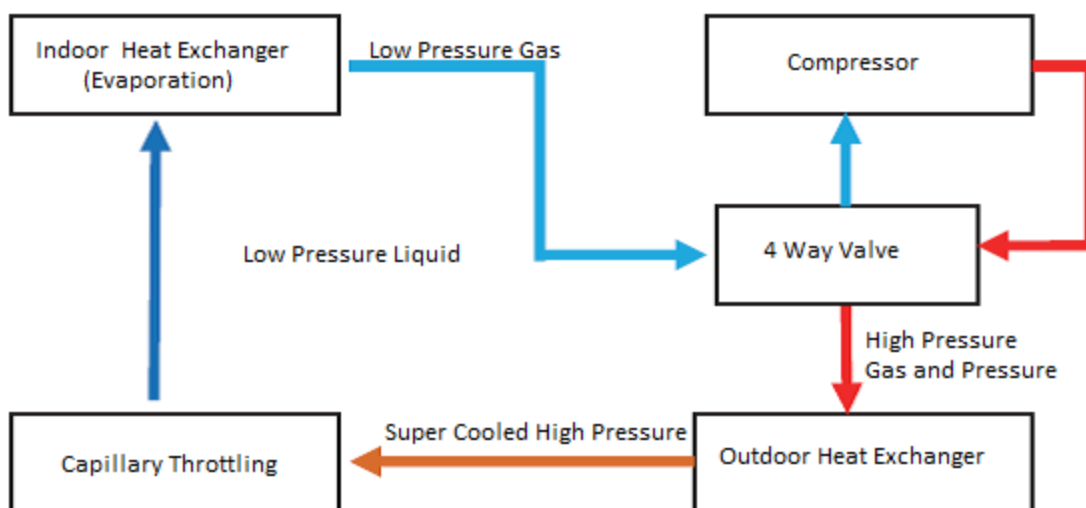

## Heating Mode

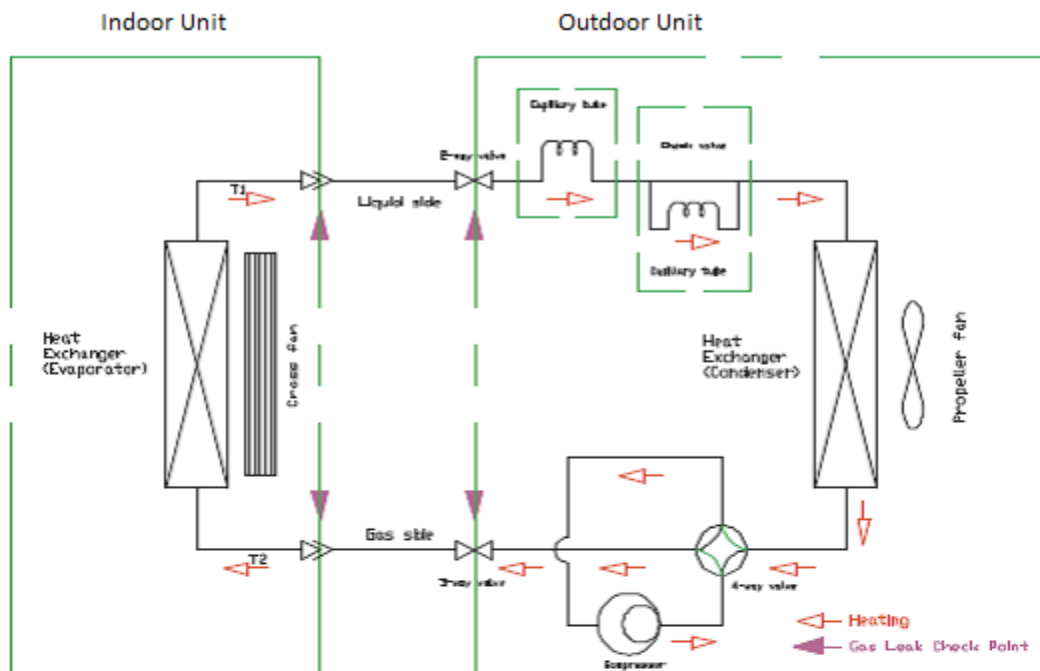

## Heating Cycle

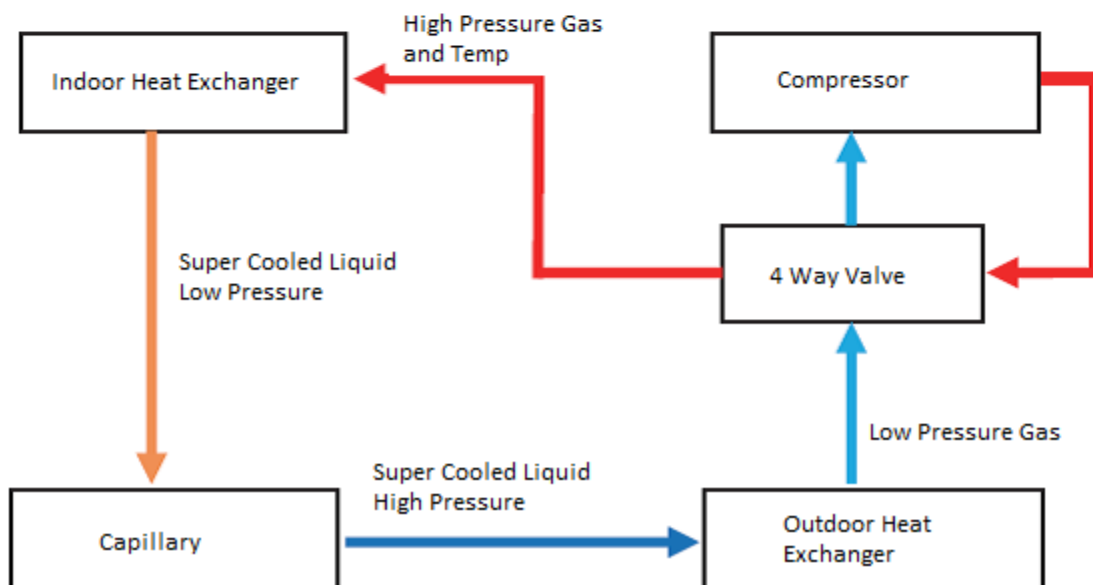

## 5. Schematic Diagram

### 5.1 Indoor unit electrical wiring

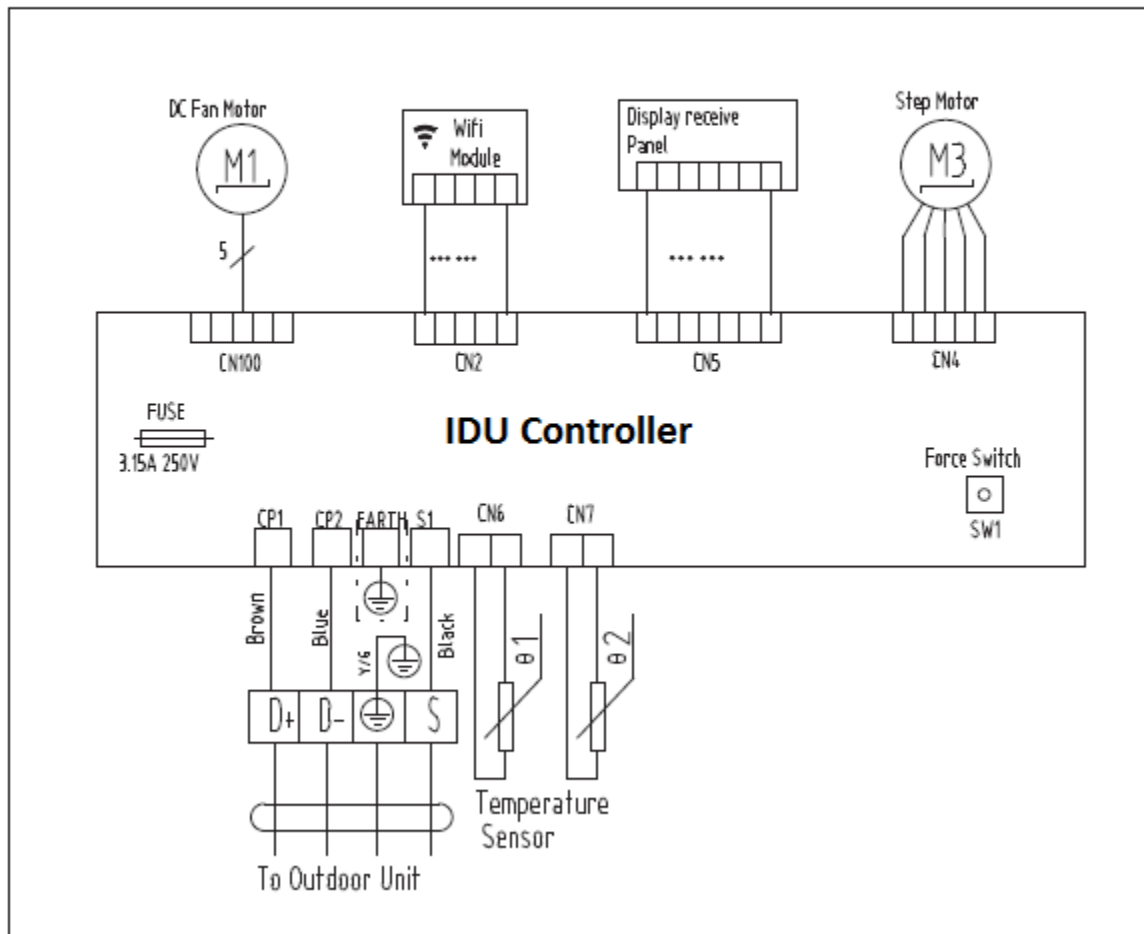

## 5.2 Outdoor unit electrical wiring

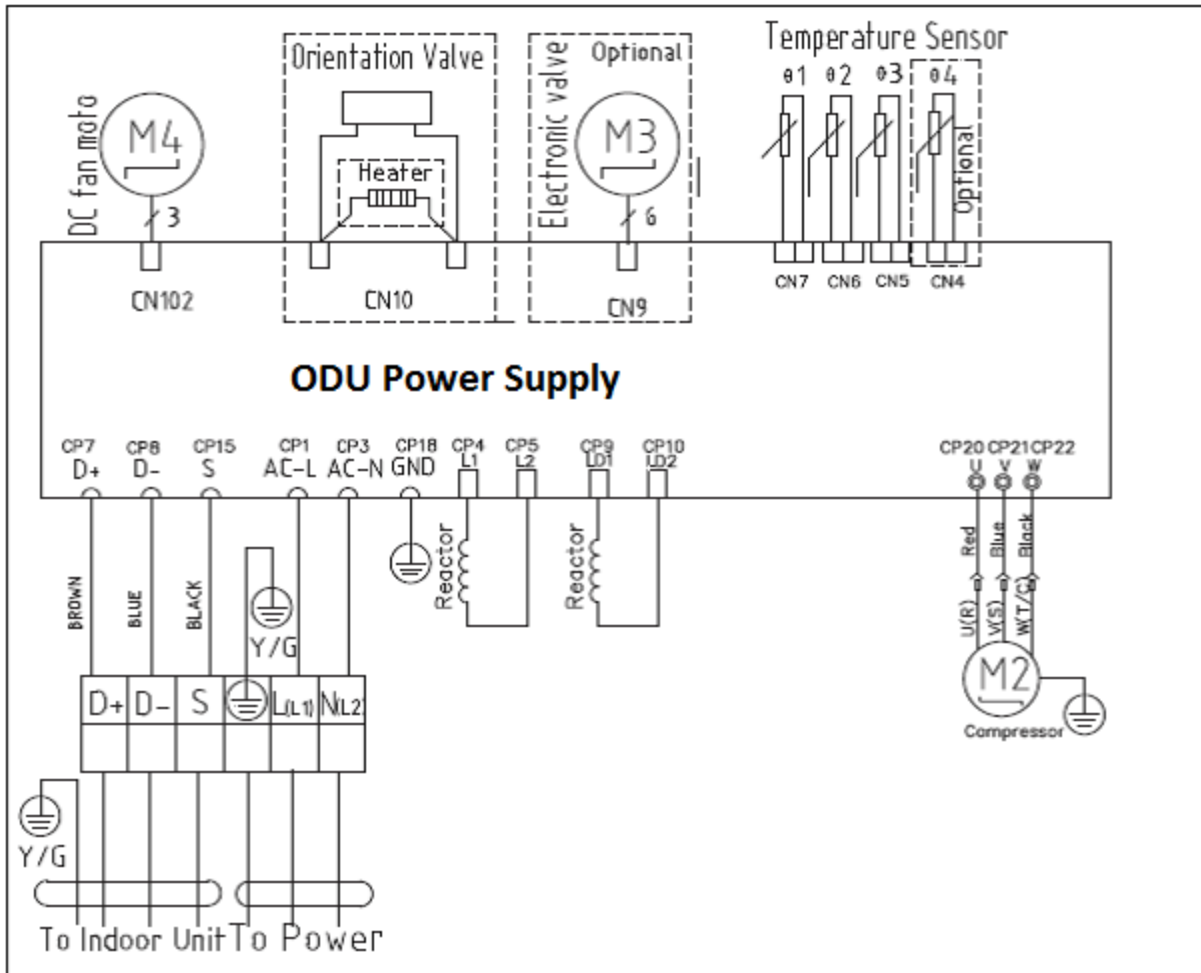

## 6. Function and Control

### 6.1 Remote Control Operations

#### Handing the remote controller

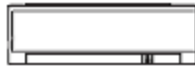

Location of the remote controller.

- Use the remote controller within a distance of 8 meters from the appliance, pointing it towards the receiver. Reception is confirmed by a beep.
- Keep the remote controller where its signals can reach the receiver of the unit.

#### ⚠ CAUTIONS

- The air conditioner will not operate if curtains, doors or other materials block the signals from the remote controller to the indoor unit.
- Prevent any liquid from falling into the remote controller. Do not expose the remote controller to direct sunlight or heat.
- If the infrared signal receiver on the indoor unit is exposed to direct sunlight, the air conditioner may not function properly. Use curtains to prevent the sunlight from falling on the receiver.
- If other electrical appliances react to the remote controller, either move these appliances or consult your local dealer.

#### Replacing batteries

The remote controller is powered by two dry batteries housed in the rear part and protected by a cover.

- (1) Remove the cover by pressing and sliding off.
- (2) Remove the old batteries and insert the new batteries, placing the (+) and (-) ends correctly.
- (3) Reattach the cover by sliding it back into position.

NOTE: When the batteries are removed, the remote controller erases all programming. After inserting new batteries, the remote controller must be reprogrammed.

#### ⚠ CAUTIONS

- Do not mix old and new batteries or batteries of different types.
- Do not leave the batteries in the remote controller if they are not going to be used for 2 or 3 months.
- Do not dispose batteries as unsorted municipal waste. Collection of such waste separately for special treatment is necessary.

#### Performance Feature

1. Operating Mode: AUTO, COOL, DRY, HEAT(enabled on cooling& heating models only ) and FAN.
2. Timer Setting Function in 24 hours.
3. Indoor Setting Temperature Range : 60°F~90°F.
- 4. Full function of LCD (Liquid Crystal Display).



## 6.2 Buttons description

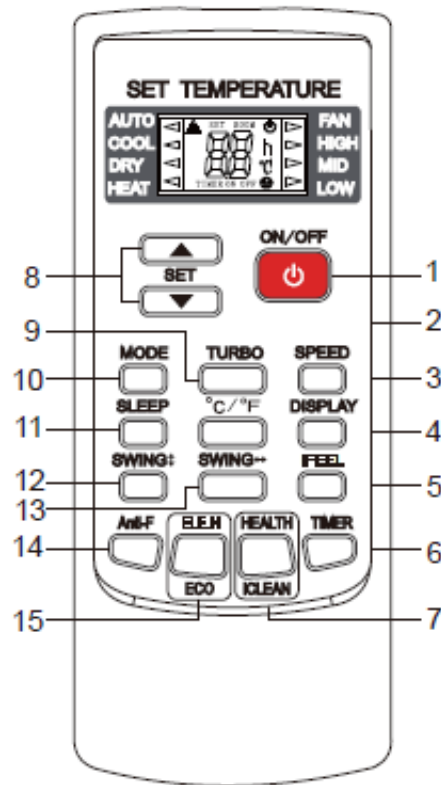

### Note:

The remote controller display all symbols during power-on and only those corresponding to current operation the rest of the time.

### ON/OFF

- \* Press this button to turn on/off the unit.
- \* This will clear the existing timer and SLEEP settings.

### °C/°F

- \* Press this button to set the temperature display to Fahrenheit, which is displayed by default in Celsius. The "°C" will not be displayed on the LCD.
- \* Press this button again to restore the temperature display to Celsius.

**Note: Temperature display in Fahrenheit is not available for some models. When temperature is displayed in Fahrenheit on the remote controller, it might be in Celsius on the unit, the function and operation of which will not be affected.**

### SPEED

- \* Press this button, you can select the fan speed as follows:

↳ Low → Mid → High → Auto

**Note: AUTO air speed is not available in FAN mode.**

### DISPLAY

- \* Press this button to turn on/off the display. This is for the convenience of users who are uncomfortable sleeping with the backlight on.

### iFEEL

- \* Press this button to set the temperature display on the remote controller to ambient temperature and press this button again to set it to preset temperature.

### TIMER

- \* With the unit ON, press this button to set OFF timer or with it OFF to set ON timer.
- \* Press this button once, a "ON(OFF)" will flash. Press "▲" or "▼" to set the number of hours in which the unit will be turned ON/OFF, with an interval of 0.5 hour if less than 10 hours, or 1 hour if longer than 10 hours, and a range of 0.5-24 hours.
- \* Press it again to confirm the setting, the "ON (OFF)" will stop flashing.
- \* If the timer button is not pressed longer than 10 seconds after the "ON (OFF)" start flashing, the timer setting will be exited.
- \* If a timer setting is confirmed, pressing this button again will cancel it.

**Note: When a ON timer is set, all function buttons (except SLEEP, DISPLAY and iFEEL can't be set ) are valid and when the ON time set is up, the unit will operate as preset.**



This button has two functions.

#### a. HEALTH

- \* Press this button with the unit ON to activate health related functions, such as negative ion, electrostatic precipitation, PM2.5 removal, etc, depending on the actual configuration of each model.
- \* Press this button again to deactivate the HEALTH function.

#### b. iCLEAN

- \* Press this button with the unit OFF, the remote controller will display "CL" and the unit will automatically clean dust off the evaporator and dry it, to increase the cooling and heating efficiency.

- \* The iCLEAN function runs for approximately 30 minutes, during which if the unit is turned on with the remote controller or this button is pressed again, the iCLEAN will be deactivated.

#### ▲ or ▼

- \* Each time the "▲" is pressed, the temperature setting will increase by 1°C and each time the "▼" is pressed, it will decrease by 1°C.
- \* The temperature setting ranges from 16°C (60°F)~32°C(90°F).

**Note:** The temperature cannot be set in AUTO or FAN mode, thus these two buttons are not functional.

#### TURBO

- \* Press this button only in COOL or HEAT mode to set TURBO on or off to speed up the cooling or heating.
- \* When TURBO is on, the air speed is HIGH.
- \* When TURBO is off, the air speed will restore to previous status.

#### MODE

- \* Press this button, you can select the running mode as follows:

┌→AUTO→COOL→DRY→HEAT→FAN┐

**Note:** HEAT mode is not available for cool only units.

#### SLEEP

- \* Press this button to enter SLEEP mode, which the unit will exit after 10 hours of continuous operation and restore to the previous status.

**Note:**The SLEEP function cannot be activated in FAN mode.

#### SWING ↓

- \* Press this button to activate up/down swing and press it again to fix the swing position.

#### SWING ↔

- \* This feature is not available at this time.

### Anti-F

- \* The Anti-F functions when the unit is turned off with the remote controller in COOL, DRY or AUTO mode. It will operate in HEAT mode (FAN mode for cool only units), with the internal fan running with weak flow for 3 minute before stop, to remove the moisture within the evaporator so as to prevent it from giving off bad smell from mold.
- \* This function is not set in the factory. You may set it or cancel it any time you want as follows: With both the unit and the remote controller OFF, point the remote controller at the unit and press "Anti-F" button once, the buzzer will sound 5 times after 5 times, indicating this function is set. Once set, this function will remain valid except when the unit is power off or until it is canceled.
- \* To cancel Anti-F:
  1. Power off the unit.
  2. With both the unit and the remote controller OFF, point the remote controller at the unit and press this button once, the buzzer will sound 3 times after 5 times, indicating this function is canceled.

#### Note:

- \* **With Anti-F activated, it is advised not to turn ON the unit again before it is fully OFF.**
- \* **Anti-F function will be invalid when OFF timer is set.**



This button has two functions.

#### a. ELE.H

- \* This feature is not available

#### b. ECO

- \* If this button is pressed in COOL mode, the unit will enter the ECO mode which has the lowest electricity consumption, and exit it automatically 8 hours after.
- \* Changing modes or turning off the remote controller will automatically cancel the ECO function.
- \* Press ECO button in ECO mode to exit this mode.

**Note:** The ECO mode only works for inverter units.

## 6.3 Usage

### ★ Replacing the Batteries



1. Slide to open the cover according to the direction indicated by the arrowhead.
2. Insert two brand new batteries (7#), and position the batteries to the right electric poles (+ & -).
3. Put back the cover.

### ★ Automatic operation mode

1. Press the "MODE" button, select the automatic operation mode.
2. By pressing the "SPEED" button, you can select the fan speed from LOW, MID, HIGH, AUTO.
3. Press the "ON/OFF" button, the air-conditioner starts to operate.
4. Press the "ON/OFF" button again, the air-conditioner stops.

**Note: In the fan operation mode, the temperature settings is non-effective.**

### ★ Cooling/Heating operation mode

1. Press the "MODE" button, select the Cooling or Heating operation mode.
2. By pressing the "▲" or "▼" button, you can set the temperature range from 16°C (60°F)~32°C (90°F), the display changes as you touch the button.
3. By pressing the "SPEED" button, you can select the fan speed from LOW, MID, HIGH, AUTO.
4. Press the "ON/OFF" button, the air-conditioner starts to operate.
5. Press the "ON/OFF" button again, the air-conditioner stops.

## ★ Fan operation mode

1. Press the "MODE" button, select the fan operation mode.
2. By pressing the "SPEED" button, you can select the fan speed from LOW, MID, HIGH.
3. Press the "ON/OFF" button, the air-conditioner starts to operate.
4. Press the "ON/OFF" button again, the air-conditioner stops.

**Note: In the fan operation mode, the temperature settings is non-effective.**

## ★ Drying operation mode

1. Press the "MODE" button, select the drying operation mode.
2. By pressing the "▲" or "▼" button, you can set the temperature range from 16°C (60°F) ~ 32°C (90°F), the display changes as you touch the button.
3. By pressing the "SPEED" button, you can select the fan speed from LOW, MID, HIGH, AUTO.
4. Press the "ON/OFF" button, the air-conditioner starts to operate.
5. Press the "ON/OFF" button again, the air-conditioner stops.

## ★ Backlight function (for remote controllers with such function only)

The remote controller has a backlight which can be turned on by pressing any button for the convenience of operation in darkness. The backlight will be automatically turned off if there is no operation within 10 seconds.

## Display Status

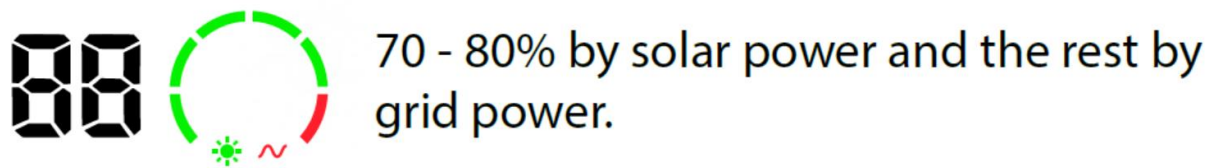
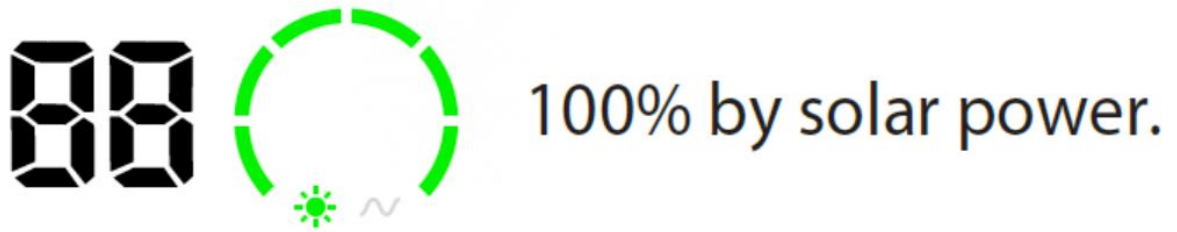

# All solar with Grid available.

## 7. Installation Manual

### 7.1 Notices for Installation

#### Caution

1. The unit should be installed only by authorized service center according to local or government regulations and in compliance with the manual.
2. Before installing, please contact with local authorized maintenance center, if the unit is not installed by the authorized service center, the malfunction may not be solved due to inconvenient contact between the user and the service personnel.
3. When removing the unit to the other place, please firstly contact with the local authorized service center.
4. Warning: before obtaining access to terminals, all supply circuits must be disconnected.
5. For appliances with y attachment, the instructions shall contain the substance of the following. If the supply cord is damaged, it must be replaced by the manufacture, its service agent or similarly qualified persons in order to avoid a hazard.
6. The appliance must be positioned so that the plug is accessible.
7. The temperature of refrigerant line will be high: please keep the interconnection cable away from the copper tube.
8. The instruction shall state the substance of the following:  
This appliance is not intended for use by persons (including children with reduced physical, sensory or mental capabilities, or lack of experience and knowledge, unless they have been given supervision or instruction concerning use of the appliance by a person responsible for their safety.  
Children should be supervised to ensure that they do not play with the appliance.

#### 7.1.1 Installation Site Instructions

Proper installation site is vital for correct and efficient operation of the unit. Avoid the following sites where:

- Strong heat sources, vapors, flammable gas or volatile liquids are emitted.



- High-frequency electro-magnetic waves are generated by radio equipment, welders and medical equipment.
- Salt-laden air prevails (such as close to coastal areas).
- The air is contaminated with industrial vapors and oils.
- The air contains Sulphur's gas such as in hot spring zones.
- Corrosion or poor air quality exists.

### **7.1.2 Installation Site of Indoor Unit**

1. The air inlet and outlet should be away from the obstructions, Ensure the air can be blown through the whole room
2. Select a site where the condensate can be easily drained out, and where it is easily connected to outdoor unit.
3. Select a place where it is out of reach of children.
4. Select a place where the wall is strong enough to withstand the full weight and vibration of the unit.
5. Be sure to leave enough space to allow access for routine maintenance, the installation site should be 150cm or more above the floor.
6. Select a place about 1m or more away from TV set or any other electric appliance.
7. Select a place where the filter can be easily taken out.
8. Make sure that the indoor unit is installed in accordance with installation dimension instructions
9. Do not use the unit in the laundry or by swimming pool etc.

### **7.1.3 Installation Site of Outdoor Unit**

1. Select a site where noise and outflow air emitted by the unit will not annoy neighbors.
2. Select a site where there is sufficient ventilation.
3. Select a site where there is no obstruction blocking the inlet and outlet.
4. The site should be able to withstand the full weight and vibration.
5. Select a dry place, but do not expose the unit to strong wind.
6. Make sure that the outdoor unit is installed in accordance with the installation instructions and is convenient for maintenance and repair.
7. The height difference between indoor and outdoor units is within 5m and the length of the connecting rubbing does not exceed 15m.
8. Select a place where it is out of reach of children.
9. Select a place where the unit does not have negative impact on pedestrians or on the city.

#### 7.1.4 Safety Precaution for Electric Appliances

1. A dedicated power supply circuit should be used in accordance with local electrical safety regulations.
2. Don't drag the power cord with excessive force.
3. The unit should be reliably earthed and connected to an exclusive earth device by the professionals.
4. The air switch must have the functions of magnetic tripping and heat tripping to prevent short circuit and overload.
5. The minimum distance between the unit and combustive surface is 1.5m.
6. The appliance shall be installed in accordance with national wiring regulations.
7. An all pole disconnection switch with a contact separation of at least 3mm in all poles should be connected in fixed wiring.

#### Note:

- **Make sure there is a suitable breaker in the panel to provide L1 & L2 in the service panel.**
- **Inadequate or incorrect electrical connections may cause electric shock or fire.**

#### 7.1.5 Grounding Requirements

1. Air conditioner is type I electric appliance. Please ensure that the unit is reliably grounded.
2. The yellow-green wire in the air conditioner is the grounding wire which cannot be used for other purposes. Improper grounding may cause electric shock.
3. The earth resistance should accord to the national electrical code.
4. The power must have reliable grounding terminal. Please do not connect the grounding wire with the following:  
Gas pipe, Sewer pipe, or other place that is considered unreliable.
5. The model and rated values of the breaker should accord with the label on the outdoor unit.

## 7.2 Installation Drawing

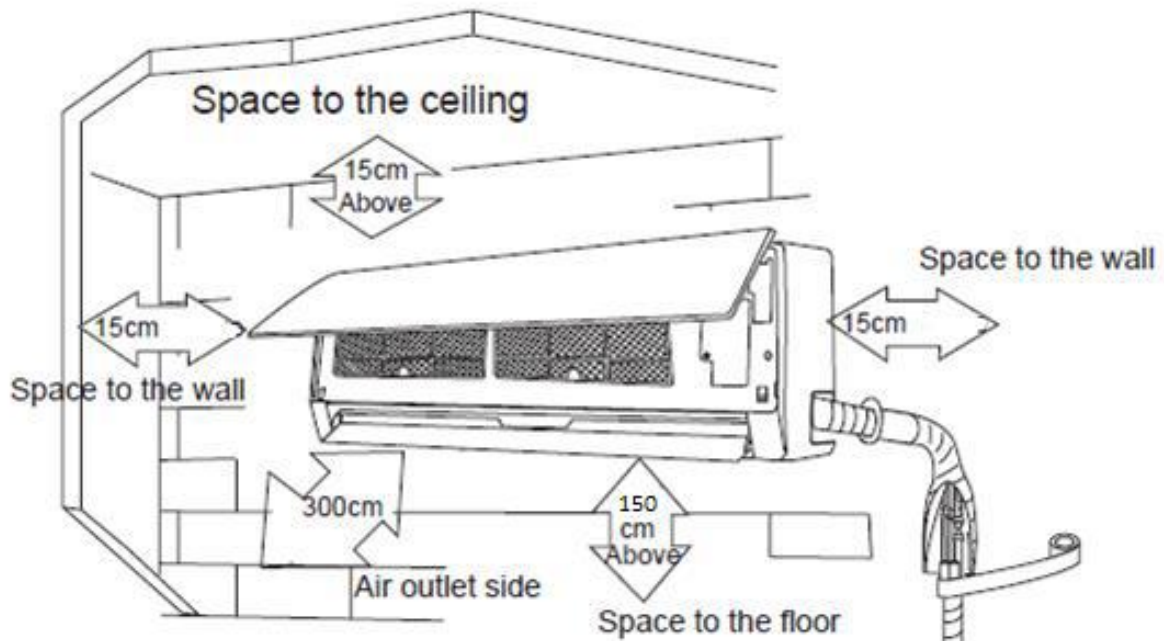

- The dimensions of the space necessary for correct installation of the appliance including the minimum permissible distances to adjacent structures

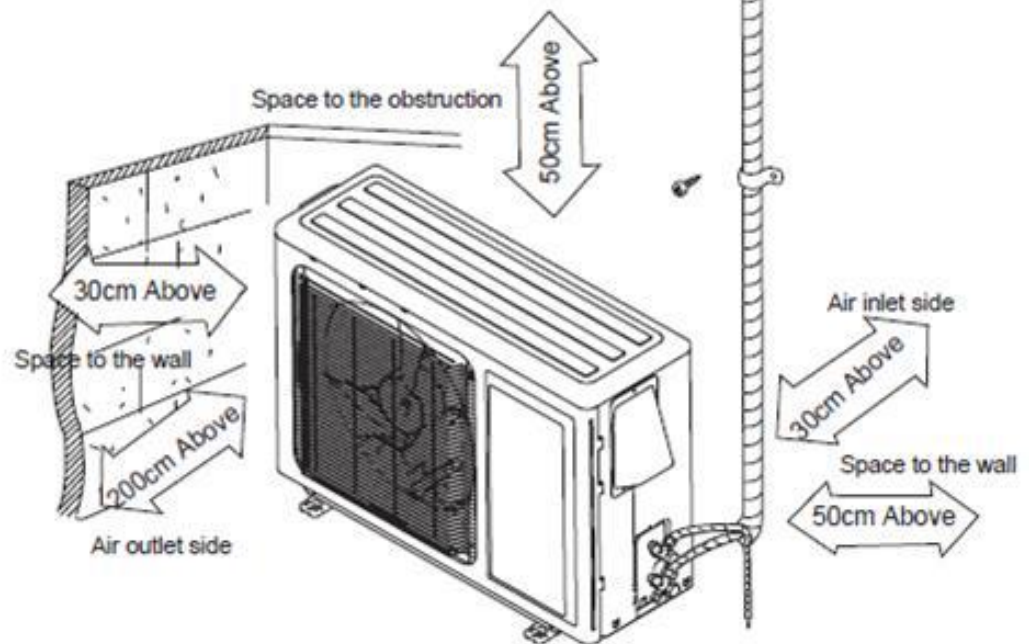

## 7.3 Install Indoor Unit

### 7.3.1 Installation of Mounting Plate

1. The mounting plate should be installed horizontally with a very slight tilt towards the drain hose. The condensation trays drain outlet can be either on the right or the left.
2. Attach the mounting plate with the supplied screws or toggle bolts (not supplied).
3. Be sure that the mounting plate is attached so it will support about 130 lbs.

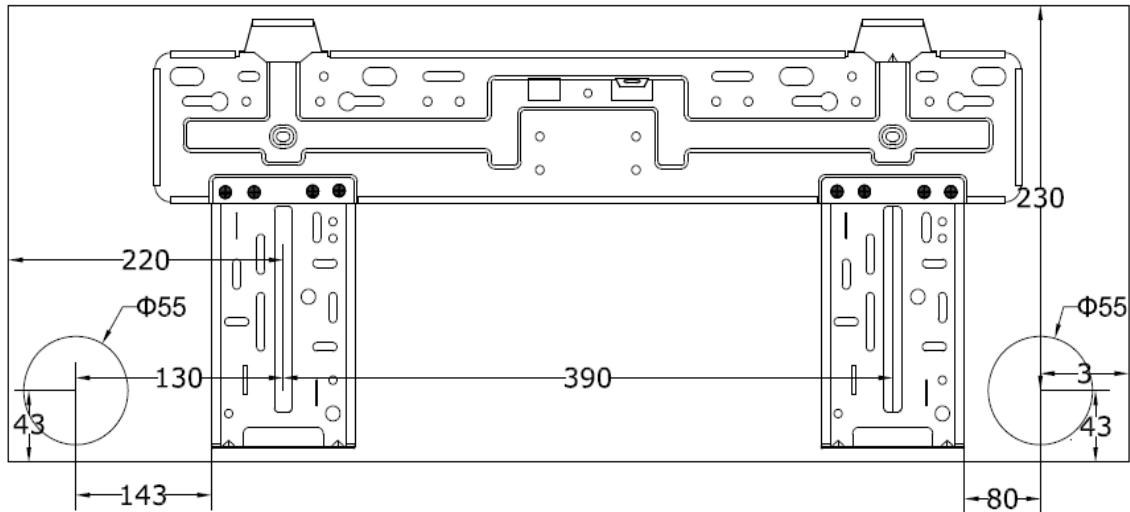

HYBRID-ACDC12-EU/US

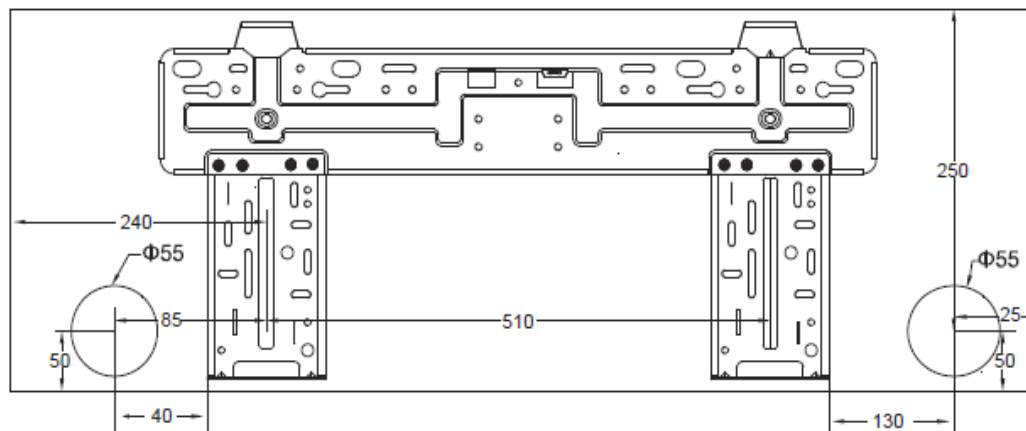

HYBRID-ACDC18-EU/US

### 7.3.2 Drilling Piping Hole

1. Slant the piping hole slightly downward to the outdoor side.
2. Use a short piece of 2" pvc (if available), as a piping sleeve to prevent the line-set and cabling from getting damaged when passing through the hole.

### 7.3.3 Installation of Drain Hose

1. Connect the drain hose to the indoor unit. Use the rubber belt to secure the connection.
2. Put the drain hose into the insulating tube.
3. Wrap the insulating tube with tape to prevent shifting Or the tube. Slant the insulating tube into the wall exit hole with the tube slanting downward.

### 7.3.4 Connecting the Indoor to Outdoor Cable

1. Open the front panel.
2. Remove the wiring cover, connect the power cord to the terminal board as shown in figure 1.
3. Pass the control cable through the access hole in the rear of the unit.
4. Reinstall the cord clamp and access cover.
5. Reinstall the front cover.

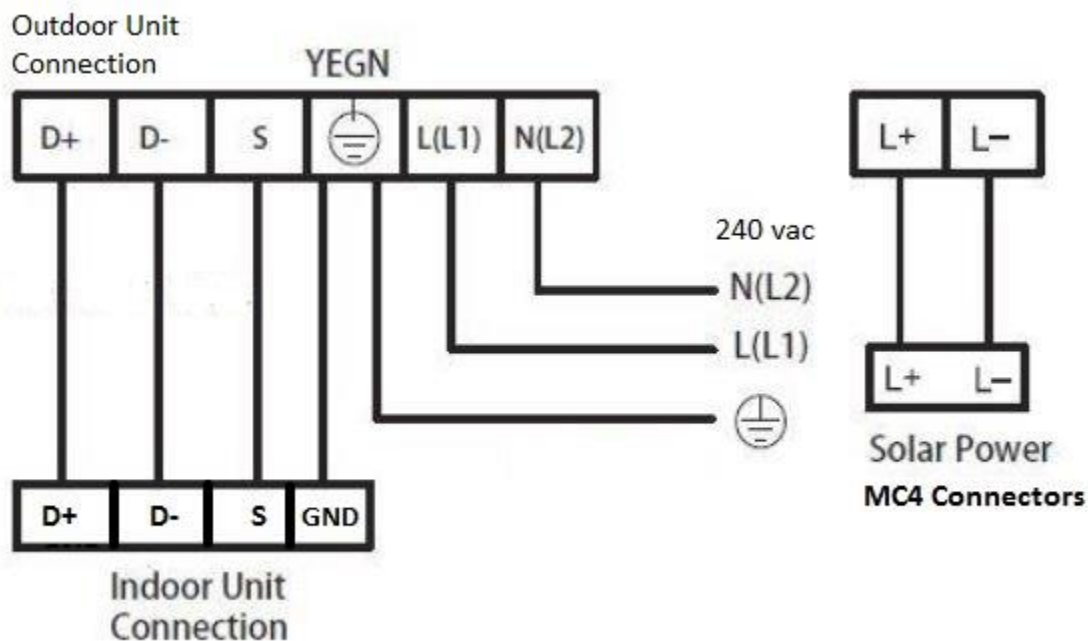

## 7.4 Install Outdoor Unit

### 7.4.1 Electric Wiring

1. Disassemble the cable securing clamps on the outdoor unit right side plate.
2. Take off the cable clamp and connect the power cable (L1 & L2).
3. Ensure wire has been secured well.
4. Install the cable cover with attaching screws.

**NOTE:**

- **Incorrect wiring may cause unit malfunction.**

**NOTE:**

**All wires between indoor and outdoor units must be connected by the qualified electric contractor.**

- Electric wire must be connected correctly. Improper connection may cause malfunction.
- Tighten the terminal screws securely.
- After tightening the screws, pull the wire slightly to confirm whether its firm or not.
- Make sure that the electric connection earthed properly to prevent electric shock.
- Make sure that all wiring connections are secure and the cover plates are reinstalled properly. Poor installation may cause fire or electric shock.

### 7.3.5 Installation of Indoor Unit

1. The piping can be output from right, right rear, left, or left rear.
2. When routing the piping and wiring from the left or right side of indoor unit, cut off the tailings from the chassis when necessary (As shown in fig 3.)
  1. Cut off tailing 1 where routing the wiring only.
  2. Cut off tailing 1 and tailing 2 when routing both the wiring and piping.
3. Pull out the line set, control cable and condensate hose from the body case. Wrap the line set control cable and condensate hose with the flashing tape.
4. Holding the sides of the indoor unit on the upper hooks of the mounting points, check if it is securely fastened.

### 7.3.6 Installation of Connection Pipe (line set)

1. Align the center of the pipe flair with the flair valve.
2. Screw in the flair nut by hand and then tighten the nut with a spanner and torque wrench by referring to the following.

Pipe Size	Torque	Model
6.35mm (1/4")	13.27 ft. lbs	ACDC12c&18C
9.52mm (3/8")	30.97 ft. lbs	ACDC12C
15.88mm (5/8")	40.56 ft. lbs	ACDC18C

Additional Freon if more than 5m
ACDC12C 20 g/m
ACDC18c 30 g/m



1/4" to 5/16" adaptor, Yellow Jacket  
PN 40801

**You will need at least one of these adaptors to service the unit.**

### 7.4.2 Air Purging and Leak Test

1. Connect the blue hose from the manifold gauges to the service port on the ODU.
2. Connect the yellow hose to a vacuum pump, do not open valves at this time.
3. Fully open the Low pressure gauge handle.
4. Turn on vacuum pump and run for at least 45min. Check the gauge to see a vacuum.
5. After 45 min. turn vacuum pump off and check the gauge for leakage.
6. If the gauge holds at a negative value for 30 min, proceed to the next step. If not, re torque the flair nuts.
7. Close the low pressure gauge handle, open and then close the gas valve releasing a little Freon into the line set to eliminate the vacuum.
8. Remove the blue hose from the service valve, then open both high and low valves releasing the Freon into the line set and IDU.

## 7.5. Install PV Modules

### 7.5.1 PV Module Characteristics

Maximum Power Voltage(W)	≤ DC 4500W
Optimum operating voltage(Vmp)	DC100~ 300V
Optimum operating voltage(Vmp)	≥DC100V
Open-circuit voltage(Voc )	≤ DC 380V
Short-circuit current (Isc)	≤ DC 12A
Maximum power current(Pmax)	≤ DC 12A

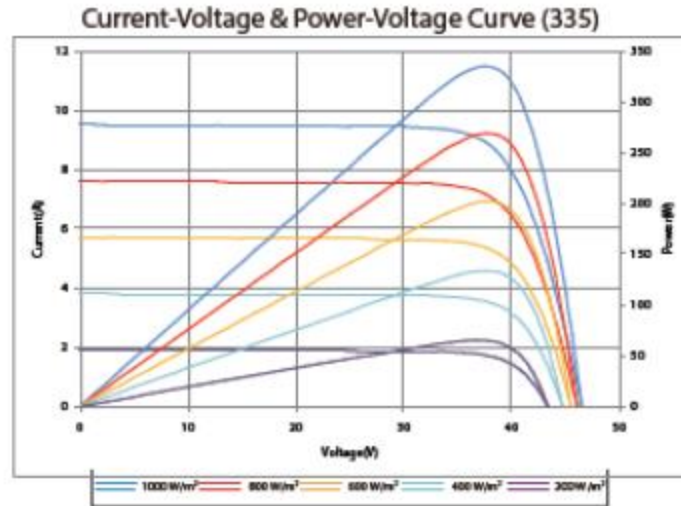

### 7.5.2 Mechanical installation

1. Mechanical installation should be carried out by a professional solar photovoltaic installer.
2. If you purchased the panels and roof racking form HotSpot you should have the installation manuals, if not please contact our technical support department for the latest versions. 757-410-8640 x112

### 7.5.3 Electrical Installation

1. Any hardware used must be compatible with the mounting structure to avoid galvanic corrosion.
2. It is not recommended to use different model pv panels in the same string.
3. All pv modules are to be connected in series. MC4 is the recommended connector.

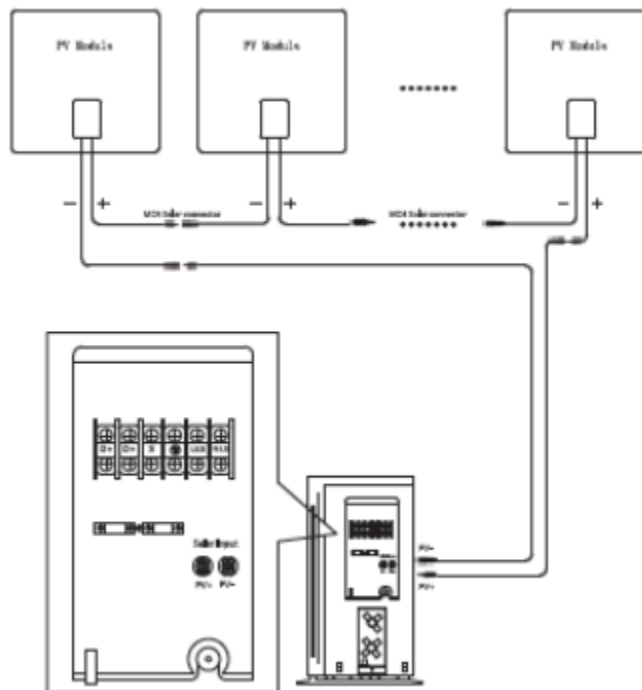



### 7.5.4 Assembly of PV-wire

1. The PV-wire should be single-pole, double insulated solar cable, the length of which is due to the distance from PV-modules to outdoor unit of AC, the recommended conductor cross section is AWG12, and it should accord with UL4703.

2. The MC-4 Connectors should be assembled to the PV-wires, and the other side of the PV-wires should be assembled with spade terminals.

MC-4connectors,

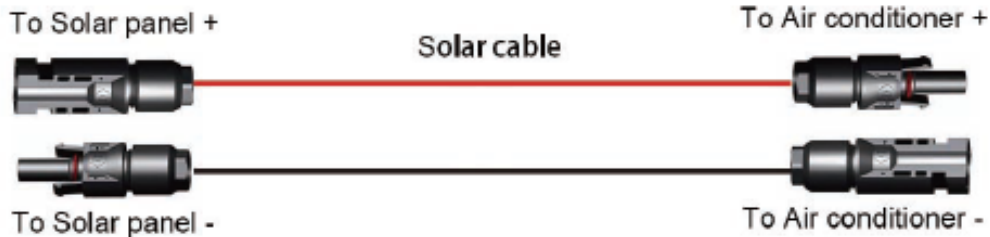

### 7.5.5 Assembly of MC-4 Connector





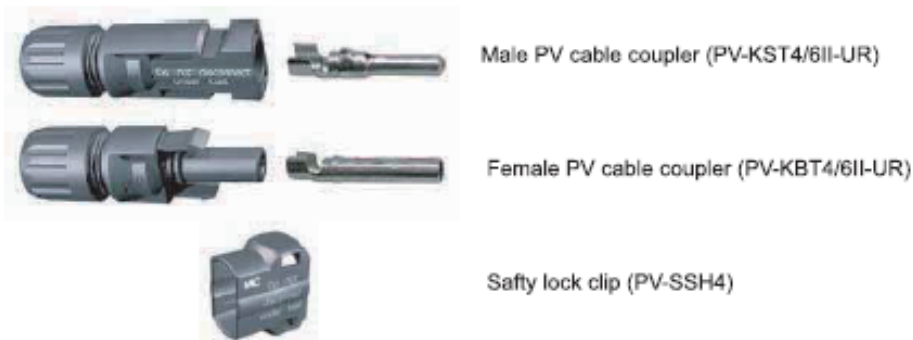



1. Introduction of MC-4 Connector





The MC-4 Connector contains three Parts, male PV cable coupler(PV-KST4/6II-UR), female PV cable coupler(PV-KBT4/6II-UR) and a safty lock clip(PV-SSH4).



2. Assembly Method

	Introduction	Photo	Recommended tool
<b>Step1</b>	Strip cable insulation. L = 6-7,5 mm. Take care not to cut individual strands.		Stripping pliers:PV-AZM-1.5/6  Interchangeable blade: PV-M-AZM-156

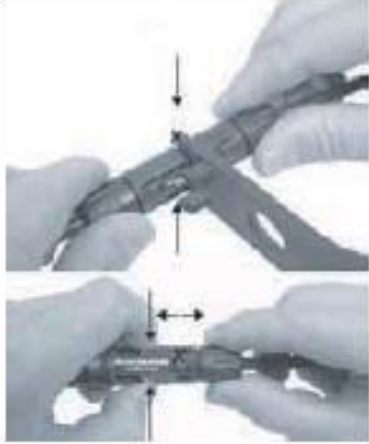
<p><b>Step2</b></p>	<p>Open and hold clamping clip (K). Insert contact in the appropriate cross-section range of the crimping tool. Turn contact till crimping tabs face the top. Release clamping clip (K). The contact is secured.</p>		<p>Crimping pliers: PV-CZM-19100</p>  <p>Insert: PV-ES-CZM-19100</p>  <p>Locator: PV-LOC</p> 
<p><b>Step3</b></p>	<p>Lightly press the pliers together so that the crimping tabs lie securely within the crimping die.</p>		
<p><b>Step4</b></p>	<p>Insert the stripped cable until the insulation comes into contact with the crimping insert. Close crimping tool completely. Check crimp.</p>		
<p><b>Step5</b></p>	<p>Push the crimped contact into the socket resp. plug insulator until it engages. Pull lightly on the lead to check that the metal part has engaged.</p>		
<p><b>Step6</b></p>	<p>Insert the test pin with the corresponding side into the socket or plug to the end position. If the contact is correctly assembled, the white marking on the test pin must be still visible.</p>	 <p>if black white marking change black</p>	<p>Test plug PV-PST</p> 

<p><b>Step7</b></p>	<p>Screw on the cable gland, hand-tight, with the tools PV-MS.</p> <p>The tightening torque must be adapted to the solar cables used in each specific case. Typical values lie in a range between 2,5Nm to 3Nm.</p>		<p>Open-end spanner PV-MS 1 set = 2 pieces</p> 
<p><b>Step8</b></p>	<p>Plug the coupling together until they engage. Check correct engagement by pulling on the coupling.</p>		
<p><b>Step9</b></p>	<p>Compress the two snapin springs (X) by hand or with the PV-MS tool and separate the coupling.</p>		
<p><b>Step10</b></p>	<p>Plugging: Mount the plug connection until it engages. Check correct engagement by pulling on the coupling.</p> <p>Unplugging: The plug connection can only be unlocked with the tool PV-MS.</p>	<p>PV-SSH4</p> 	<p>PV-SSH4</p> 

## 7.6 Check after Installation and Operation Test

### 7.6.1 Check after Installation

Items to be checked	Possible malfunction
Has it been fixed firmly?	The unit may drop, shake or emit noise.
Have you done the refrigerant leakage test?	It may cause insufficient cooling(heating) capacity
Is heat insulation sufficient?	It may cause condensation and dripping.
Is water drainage satisfactory?	It may cause condensation and dripping.
Is the voltage in accordance with the rated voltage marked on the nameplate?	It may cause electric malfunction or damage the product.
Is the electric wiring and piping connection installed correctly and securely?	It may cause electric malfunction or damage the part.
Has the unit been connected to a secure earth connection?	It may cause electrical leakage.
Is the power cord specified?	It may cause electric malfunction or damage the part.
Are the inlet and outlet openings blocked?	It may cause insufficient cooling(heating) capacity.
Is the length of connection pipes and refrigerant capacity been recorded?	The refrigerant capacity is not accurate.

### 7.6.2 Operation Test

#### 1. Before Operation Test

- (1) Do not switch on power before installation is finished completely.
- (2) Electric wiring must be connected correctly and securely.
- (3) Cut-off valves of the connection pipes should be opened.
- (4) All the impurities such as scraps and thrums must be cleared from the unit.

#### 2. Operation Test Method

- (1) Switch on power and press "ON/OFF" button on the remote controller to start operation.
- (2) Press MODE button to select the COOL, HEAT (Not available for cooling only unit), FAN to check whether the operation is normal or not.

## 7.7 Installation and Maintenance of Air Filters

### 7.7.1 Removal and installation of the air filters.

1. Lift up the front panel from its two ends, as shown by the arrow direction, and then remove the air filters. (As shown in fig a)
2. Install the air filter properly along the arrow direction in Fig.c, and then close the panel.

### 7.7.2 Cleaning and Maintenance

Remove the filter and reinstall it after cleaning according to the installation instruction. Don't use brush or hard things to clean the filter. After cleaning, be sure to dry it in the shade.

### 7.7.3 Service Life

The general service life for the filter is about one year under normal condition.

• This supplementary instruction is provided for reference to the unit with filter.

If the graphics provided herein is different from the actual product, please refer to the actual product. The quantity of healthy filters is based on the actual delivery.

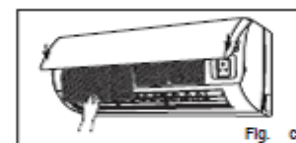
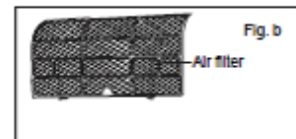
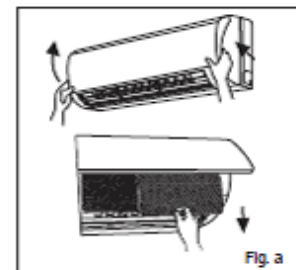

# 8. Exploded View

## 8.1 Indoor Unit

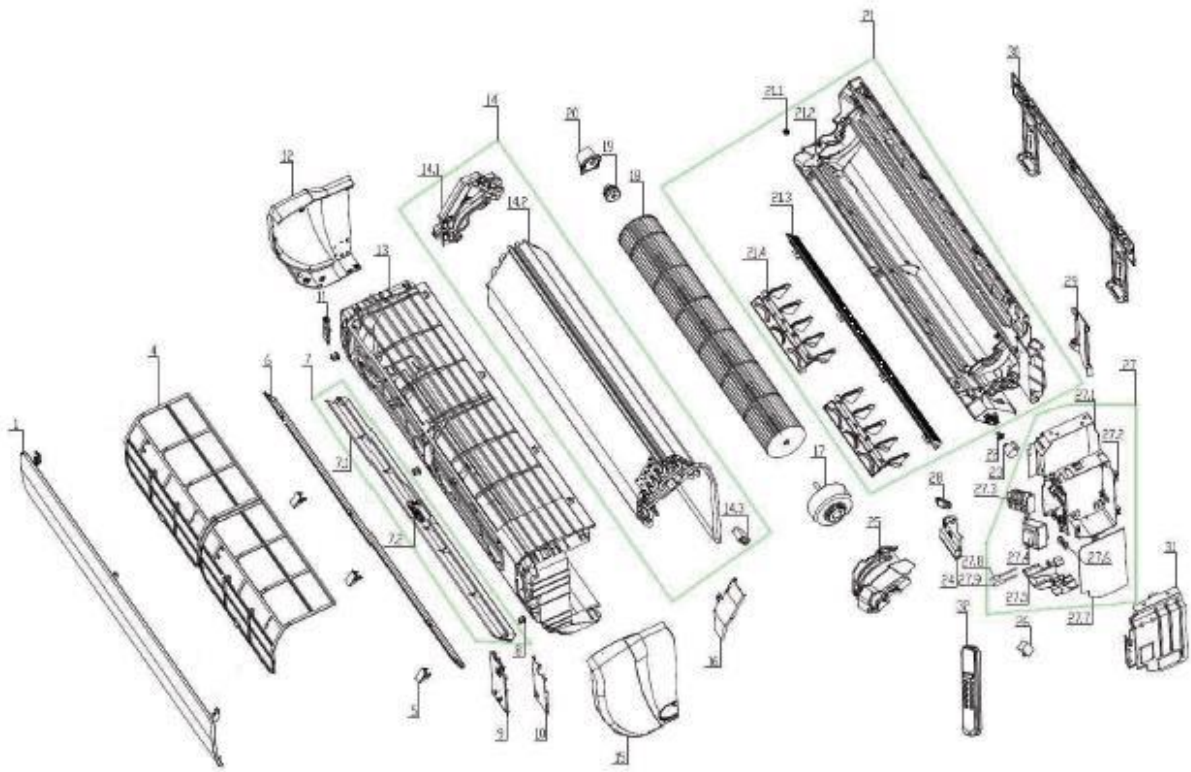

# 8.2 Outdoor Unit

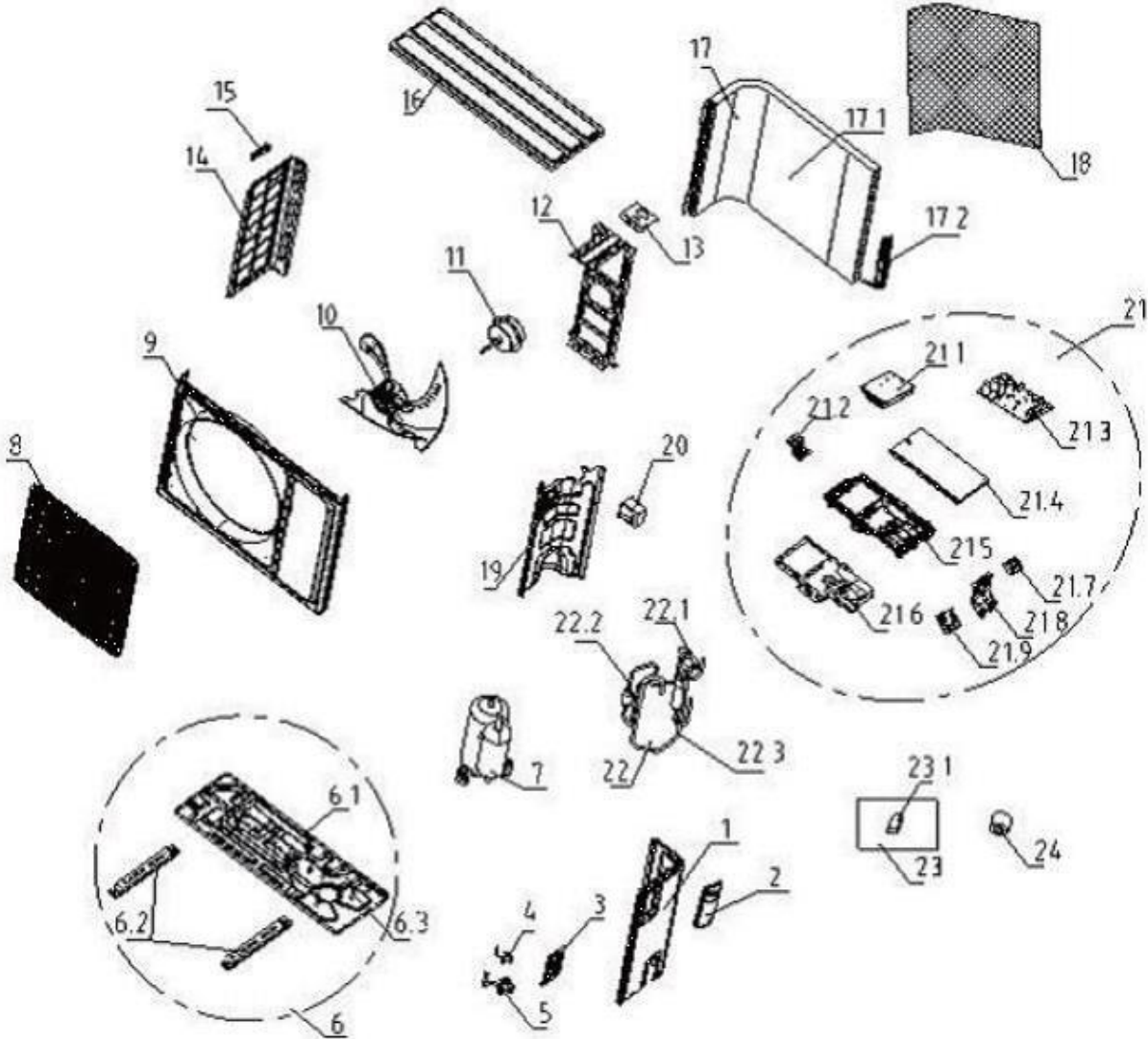

## 9. Troubleshooting

### 9.1 Error Code

Classification	Outdoor unit PCB LED blinks times	Indoor Error Code	Operation Status
Error	25	EE	Indoor EE error
	26	E1	Indoor fan error
	27	E2	IDU fan zero crossing malfunction
	28	E3	IDU coil temperature sensor error
	29	E4	IDU ambient temperature sensor error
	1	E0	ODU EE error
	2	E6	IDU & ODU communication error
	3	E7	Communication error of main board and driver board
	4	F1	Compressor start error (phase loss or reversal)
	5	F2	compressor out of step error
	6	F3	IPM error
	7	F4	Compressor casing top error / protection
	8	F5	ODU discharge temperature sensor error
	9	F6	Compressor suction temperature sensor error
	10	F7	ODU coil temperature sensor error
11	F8	ODU ambient temperature sensor error	
12	F9	ODU DC fan motor error	
Protection	13	P1	ODU AC over current protection
	14	P2	Overcurrent protection of phase current for compressor
	15	P3	Input AC voltage too high / low protection
	16	P4	Voltage for DC bus too high / low protection
	17	P5	IPM temperature too high protection
	18	P6	high discharge temperature protection of compressor
	19	p7	IDU coil antifreezing protection shutdown under cooling mode
	20	P8	ODU coil overheat protection shutdown under cooling mode
	21	P9	IDU coil overheat protection shutdown under heating mode
	22	PC	Outdoor low ambient temperature protection shutdown under cooling mode
	23	PH	Outdoor high ambient temperature protection shutdown under heating mode
	30	Pa	Va input voltage low protection
	31	Pb	Ia over current protection